

Volvo XC60 (2008-2017)

Volvo S60 (2010-)

Volvo V60 (2010-)

Volvo XC70 (2007-)

Volvo V70 (2007-)



R55

Volvo XC60 (2008-2017)

Volvo S60 (2010-)

Volvo V60 (2010-)

Volvo XC70 (2007-)

Volvo V70 (2007-)

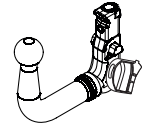
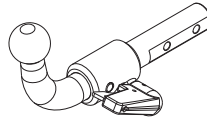
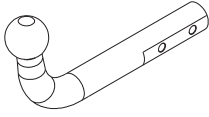

TowCar enganches **aragon**

E13 APPROVALNUMBER **55R-01 3686** D-VALUE D **11,21** kN

TYPE **VL0012** CLASS **A50-X** MAX.VERT.LOAD S **90** kg

TowCar enganches **aragon**

E13 APPROVALNUMBER **55R-01 3687** D-VALUE D **11,21** kN

TYPE **VL0013-S** CLASS **A50-X** MAX.VERT.LOAD S **90** kg

TowCar enganches **aragon**

E13 APPROVALNUMBER **55R-01 3687** D-VALUE D **11,21** kN

TYPE **VL0013-V** CLASS **A50-X** MAX.VERT.LOAD S **90** kg

D = 11,21 kN



S = 90 kg

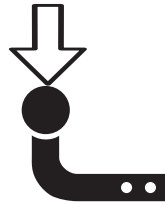

*T 2100 Kg



N/m	8,8	10,9	12,9
M6	10	15	18
M8	24	36	42
M10	51	75	87
M12	87	130	147
M14	138	198	231
M16	200	289	341

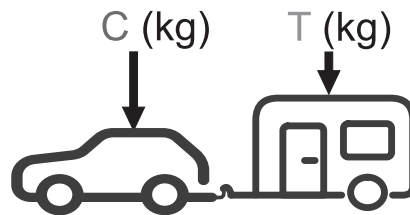

$g = 9,81 \text{ m/s}^2$

$$D \geq \frac{T \cdot C}{T + C} \cdot \frac{g}{1000} \text{ (kN)}$$

$$T \leq \frac{C \cdot D \cdot 1000}{(C \cdot g) - (1000 \cdot D)} \text{ (kg)}$$

*El MMR (T) puede variar dependiendo del vehículo.

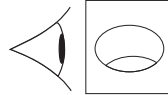
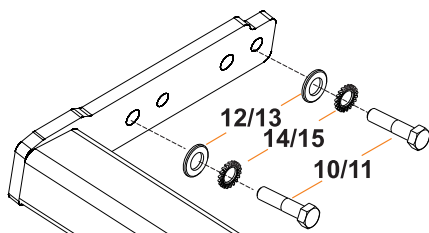

VOLVO XC60 / S60 / V60

VOLVO XC70/V70

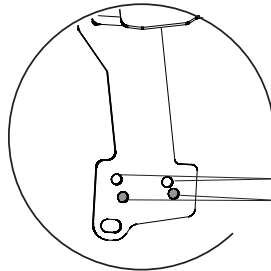
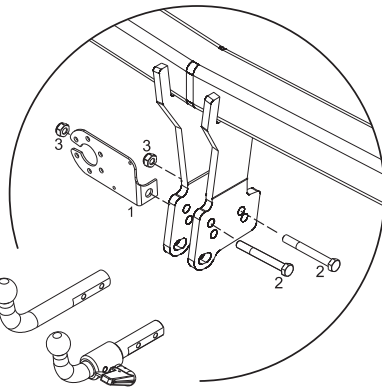
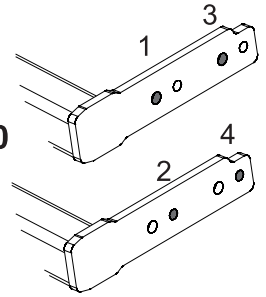

→ VOLVO S60 / V60 / V70 / XC70
→ VOLVO XC60



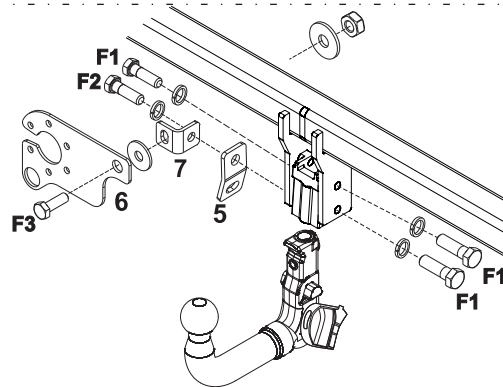





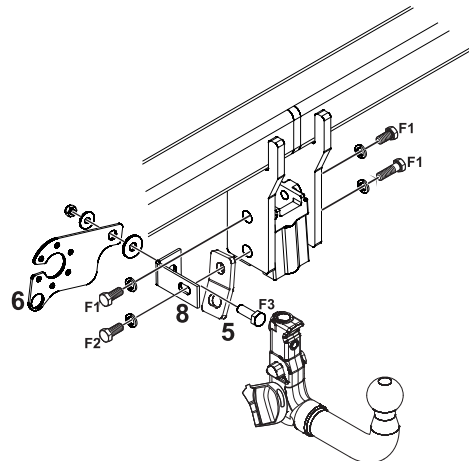

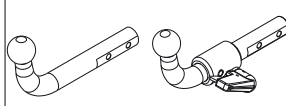
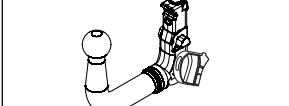



		#
F1	M12 x 25 DIN 933	3
	Ø12 Grower DIN 128	3
F2	M12 x 35 DIN 933	1
	Ø12 Grower DIN 128	1
F3	M10 x 30 DIN 933	1
	Ø10 Poliuretano / Nylon	1
	Ø10 DIN 9021	1
	M10 DIN 980	1

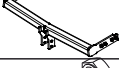

***VOLVO XC60 (07-2013→)**

		#
F1	M12 x 25 DIN 933	3
	Ø12 Grower DIN 128	3
F2	M12 x 35 DIN 933	1
	Ø12 Grower DIN 128	1
F3	M10 x 30 DIN 933	1
	Ø10 Poliuretano / Nylon	1
	Ø10 DIN 9021	1
	M10 DIN 980	1



				
1		AEV0005	1	
2		M10x65 DIN 931	2	
3		M10 DIN 980	2	
4		AEV0004	1	1
5		AEV0006		1
6		AEV0009		1
7		AEV0008		1
8		SR844404 (*XC60 07-2013-->)		1
9		C6806B	1	1
10		M14x40 DIN 933 (*XC60/S60/V60)	4	4
11		M12x40 DIN 933 (*XC70/V70)	4	4
12		Ø16 DIN125 (*XC60/S60/V60)	4	4
13		Ø12 DIN 9021 (*XC70/V70)	4	4
14		Ø14 DIN 128A (*XC60/S60/V60)	4	4
15		Ø12 DIN 128A (*XC70/V70)	4	4

1

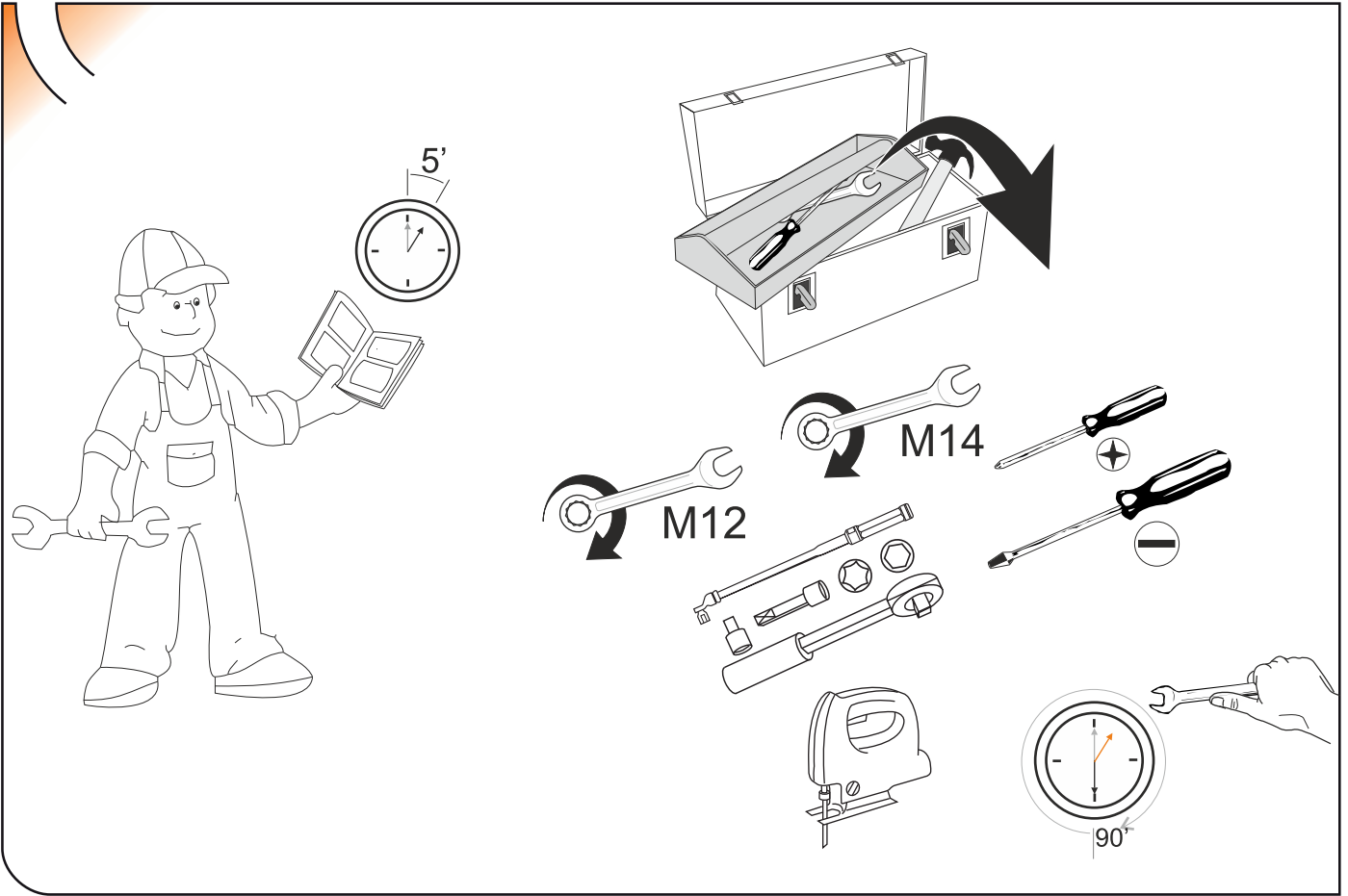

2

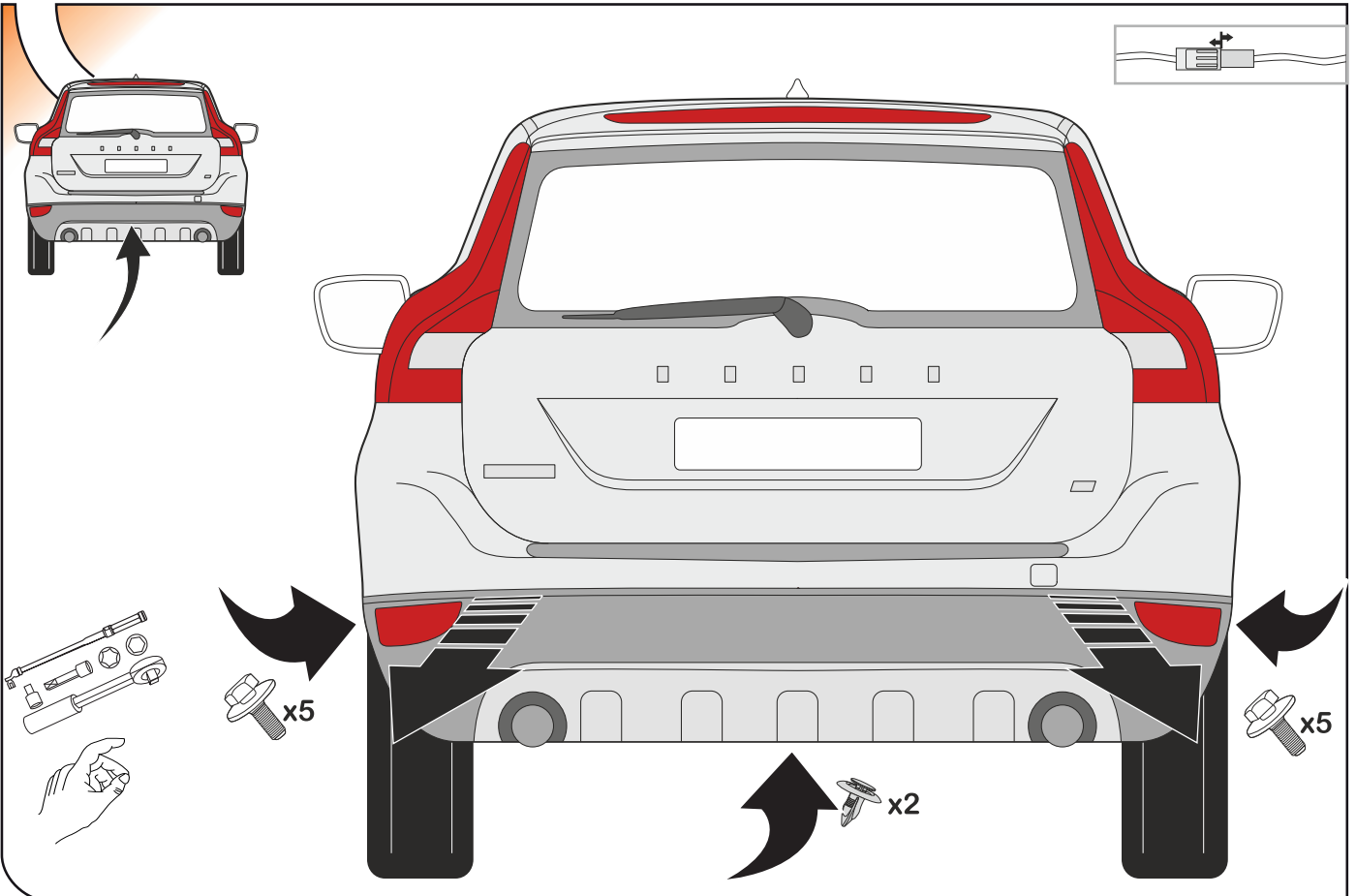

3

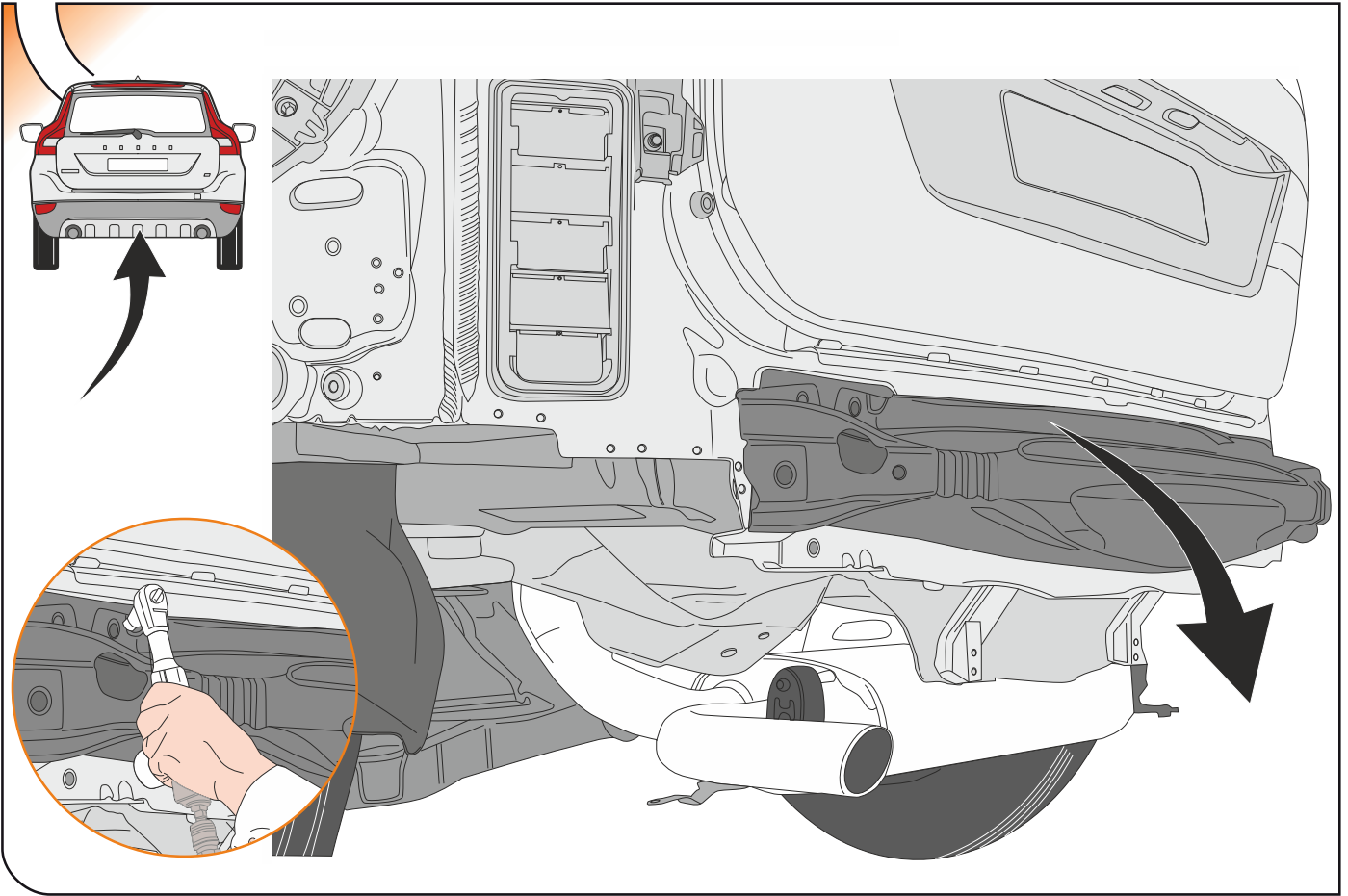

4

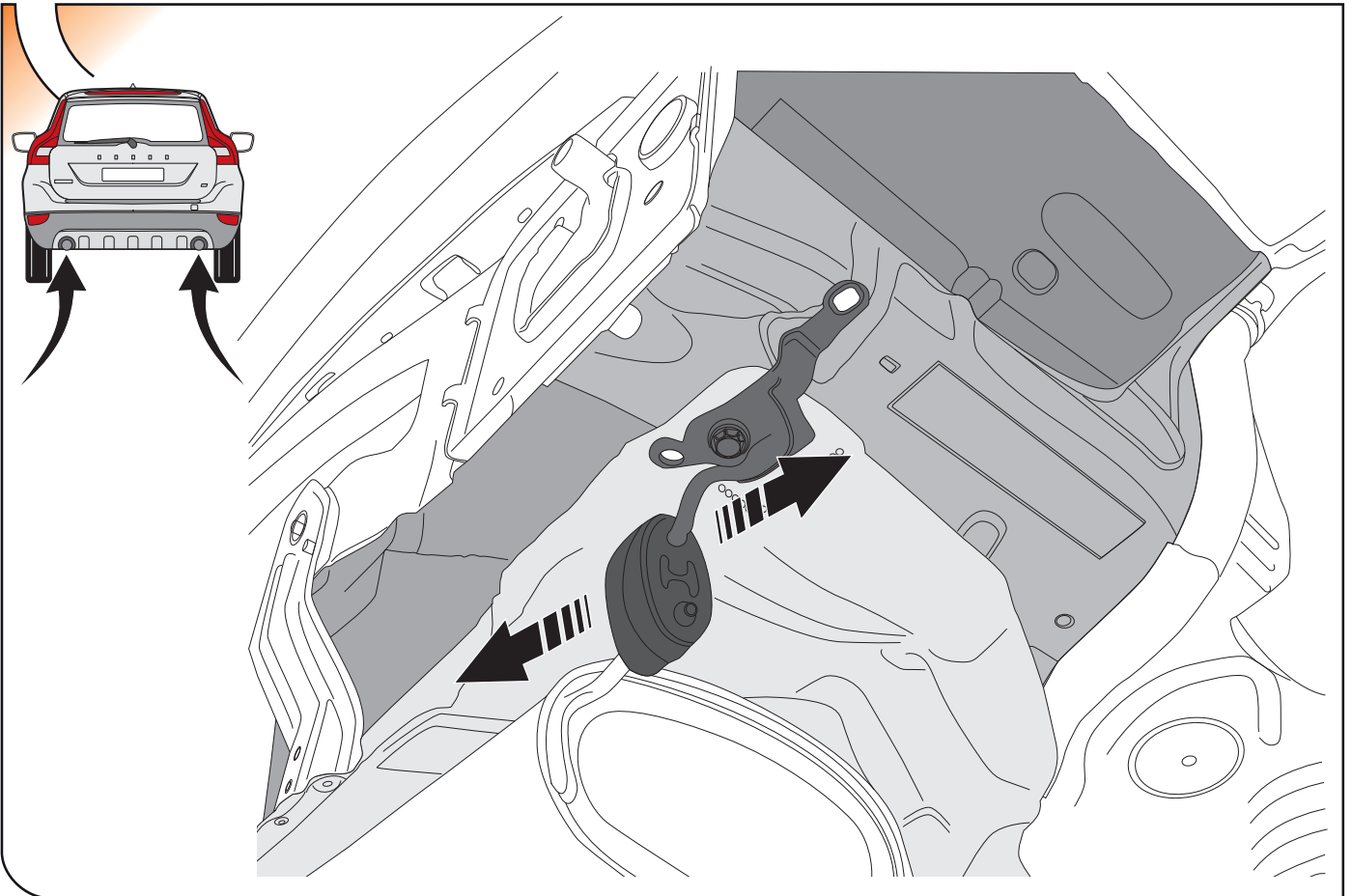

5

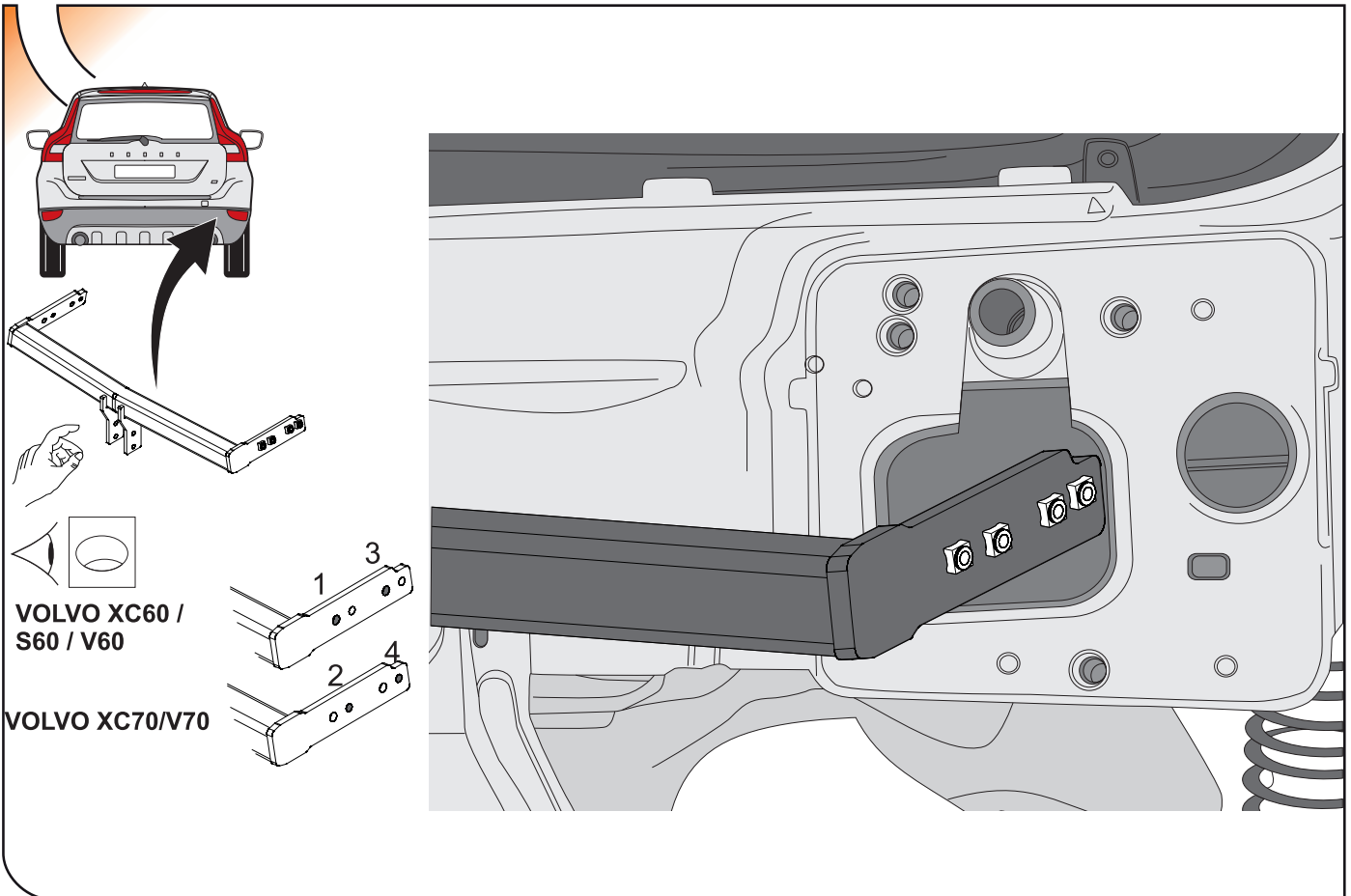





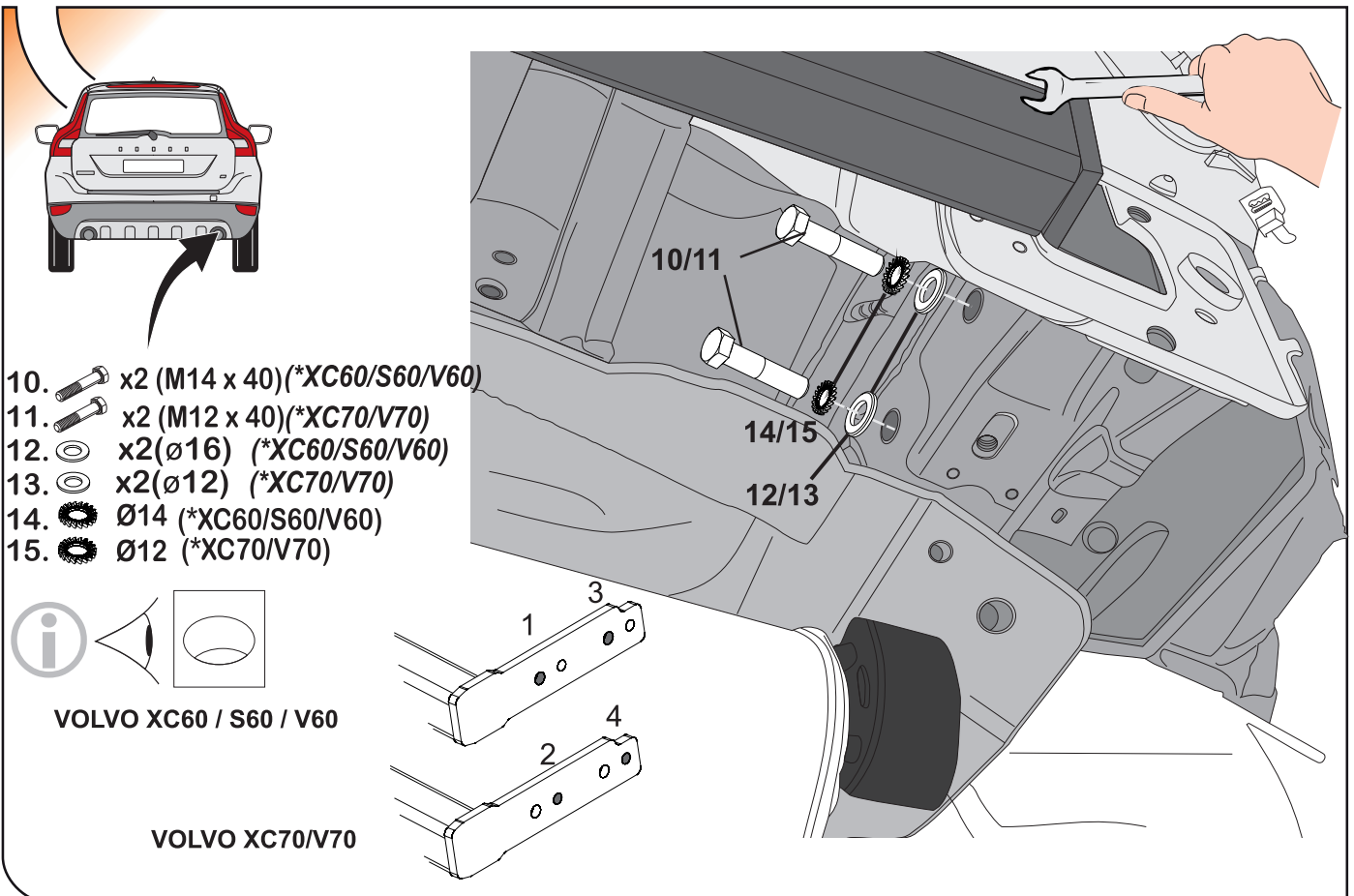

VOLVO XC60 / S60 / V60

VOLVO XC70/V70

6



- 10.  x2 (M14 x 40) (*XC60/S60/V60)
- 11.  x2 (M12 x 40) (*XC70/V70)
- 12.  x2 (Ø16) (*XC60/S60/V60)
- 13.  x2 (Ø12) (*XC70/V70)
- 14.  Ø14 (*XC60/S60/V60)
- 15.  Ø12 (*XC70/V70)

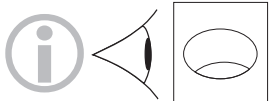

VOLVO XC60 / S60 / V60

VOLVO XC70/V70

7

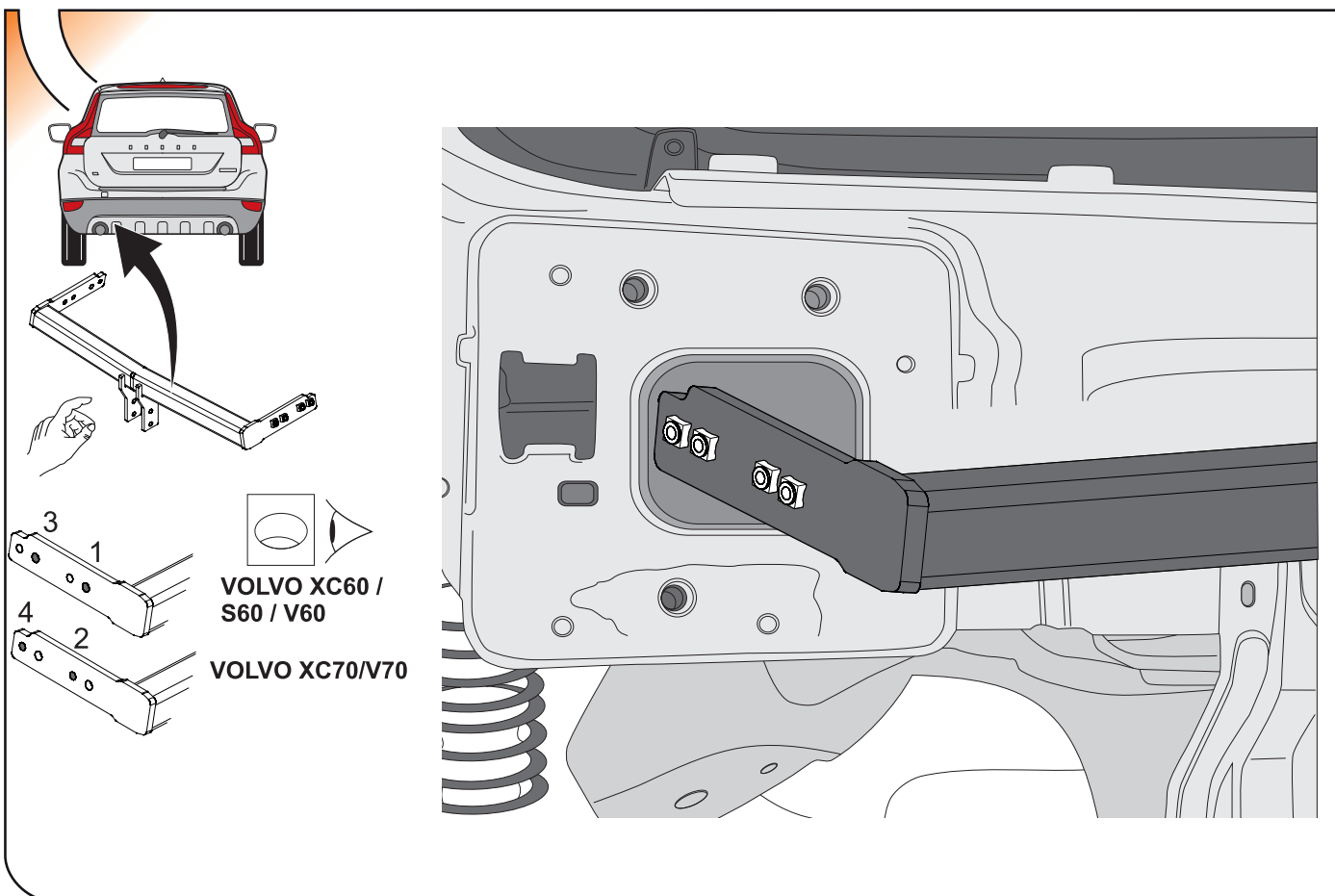

8

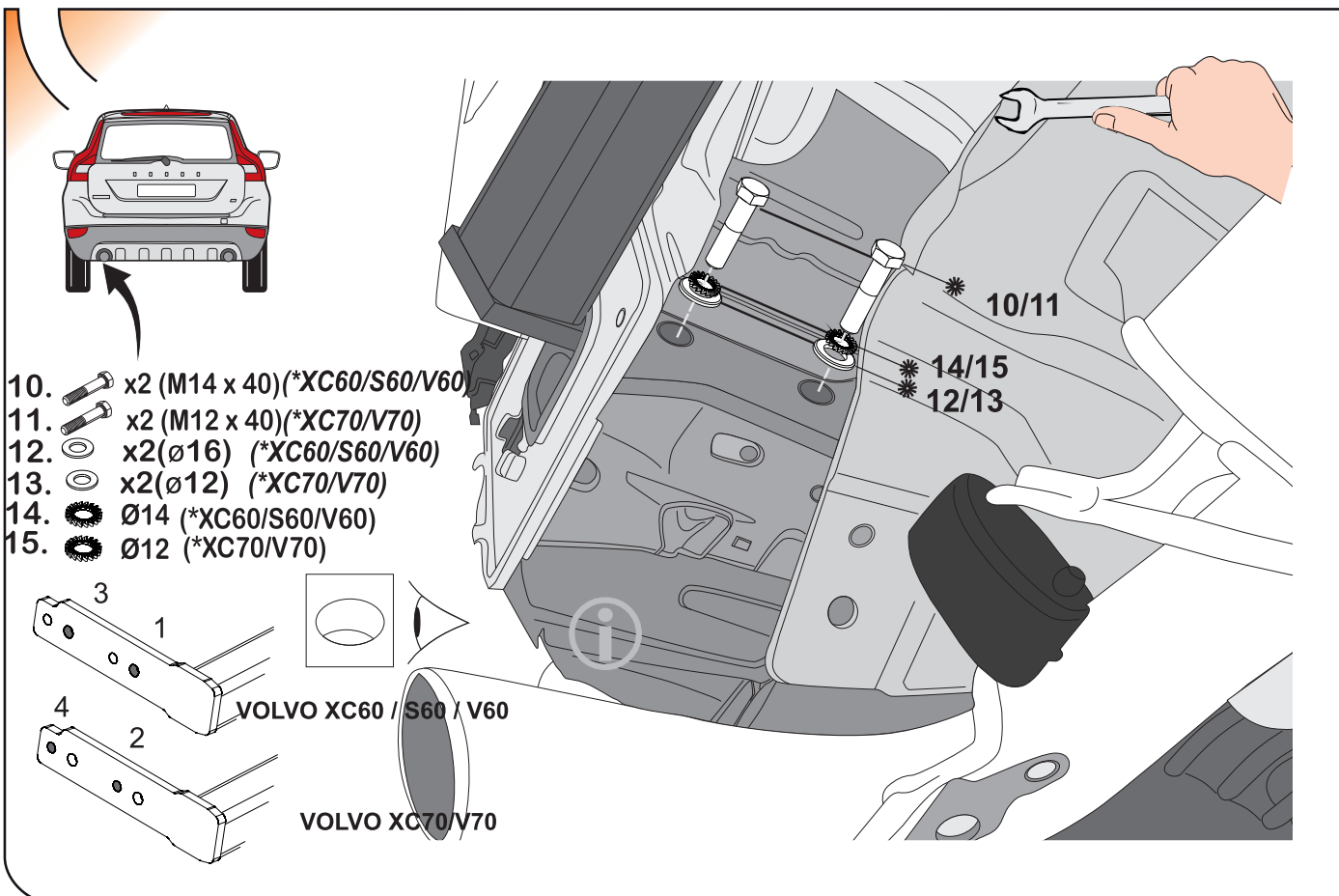

9

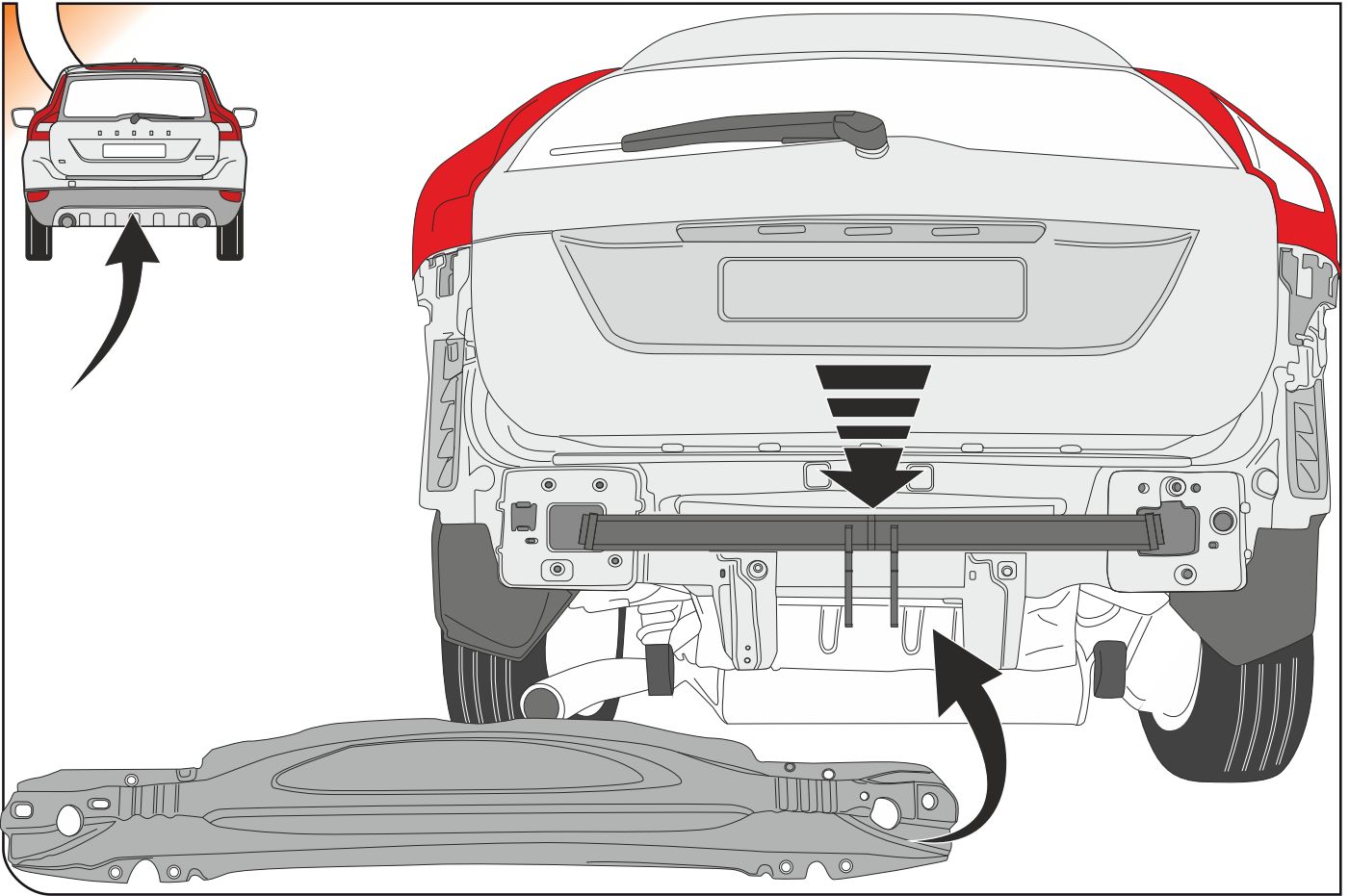

10

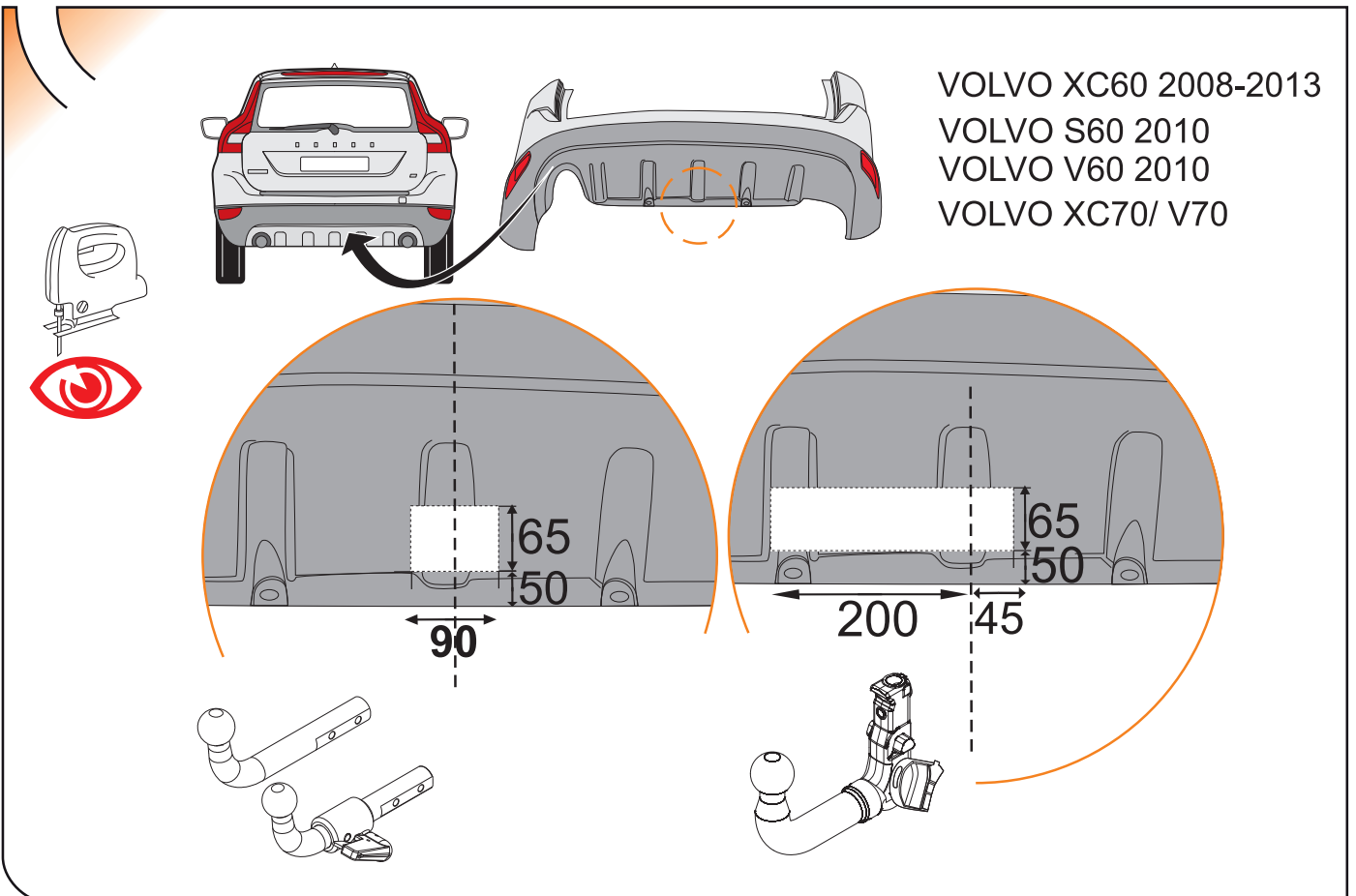

11

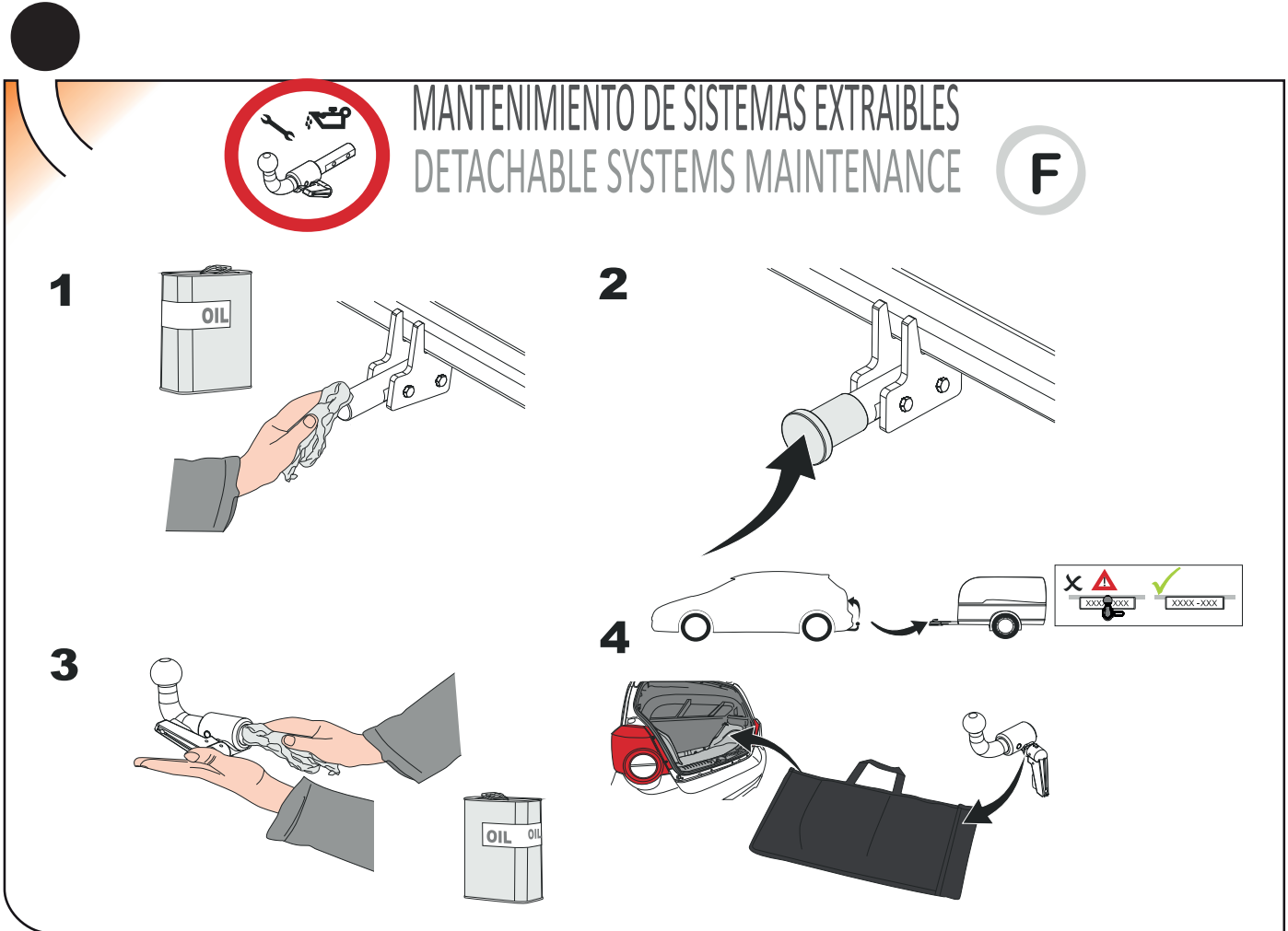
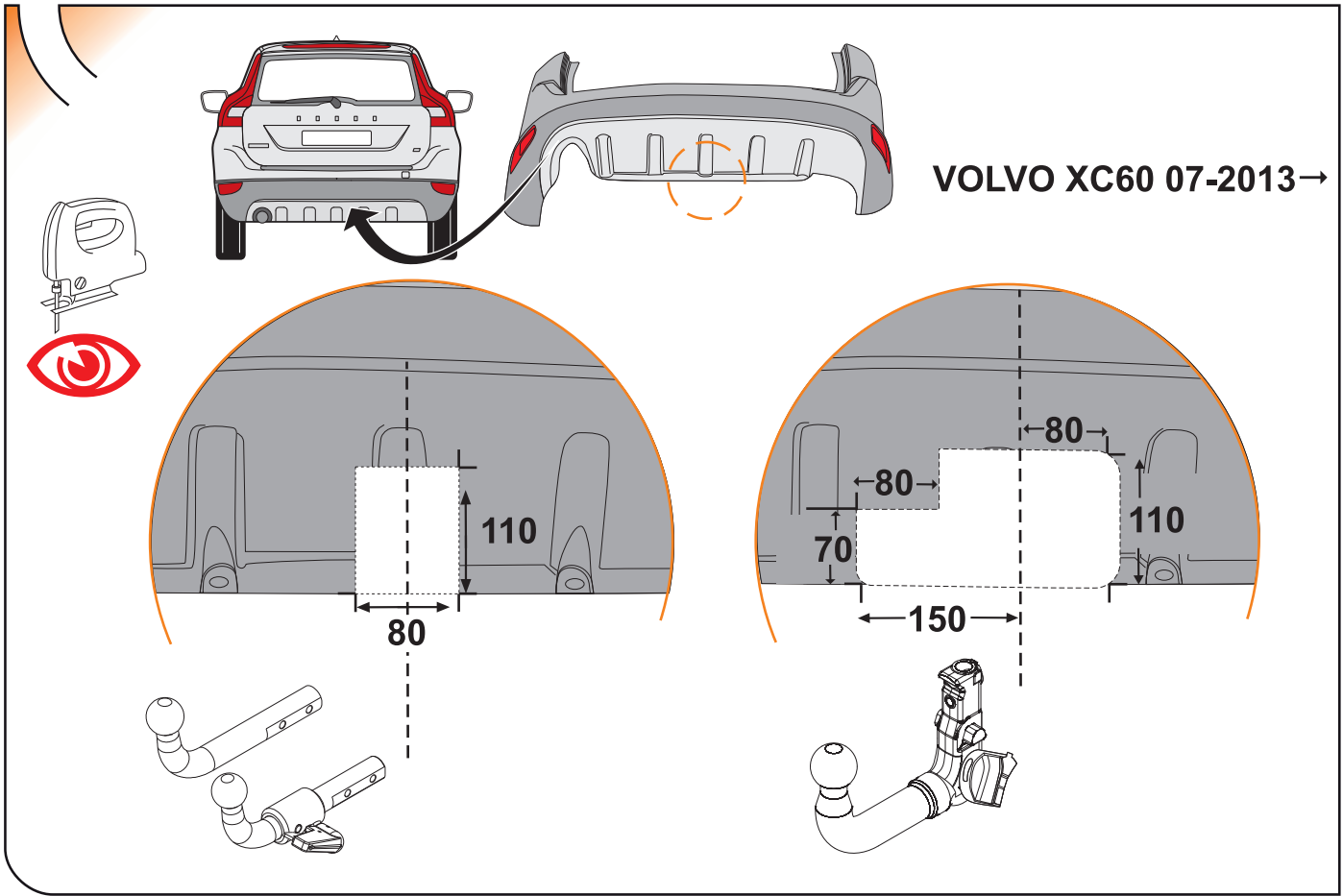

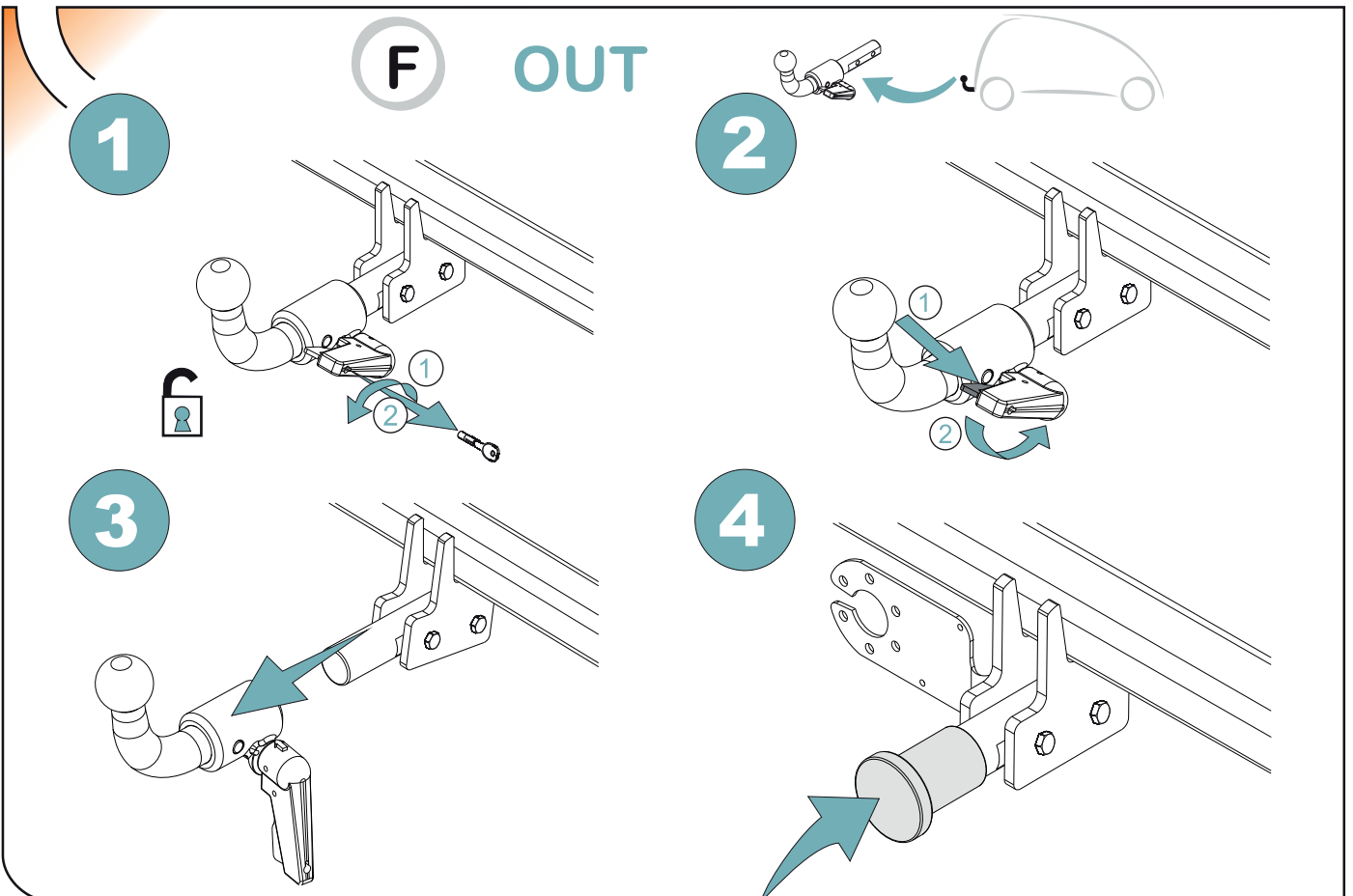
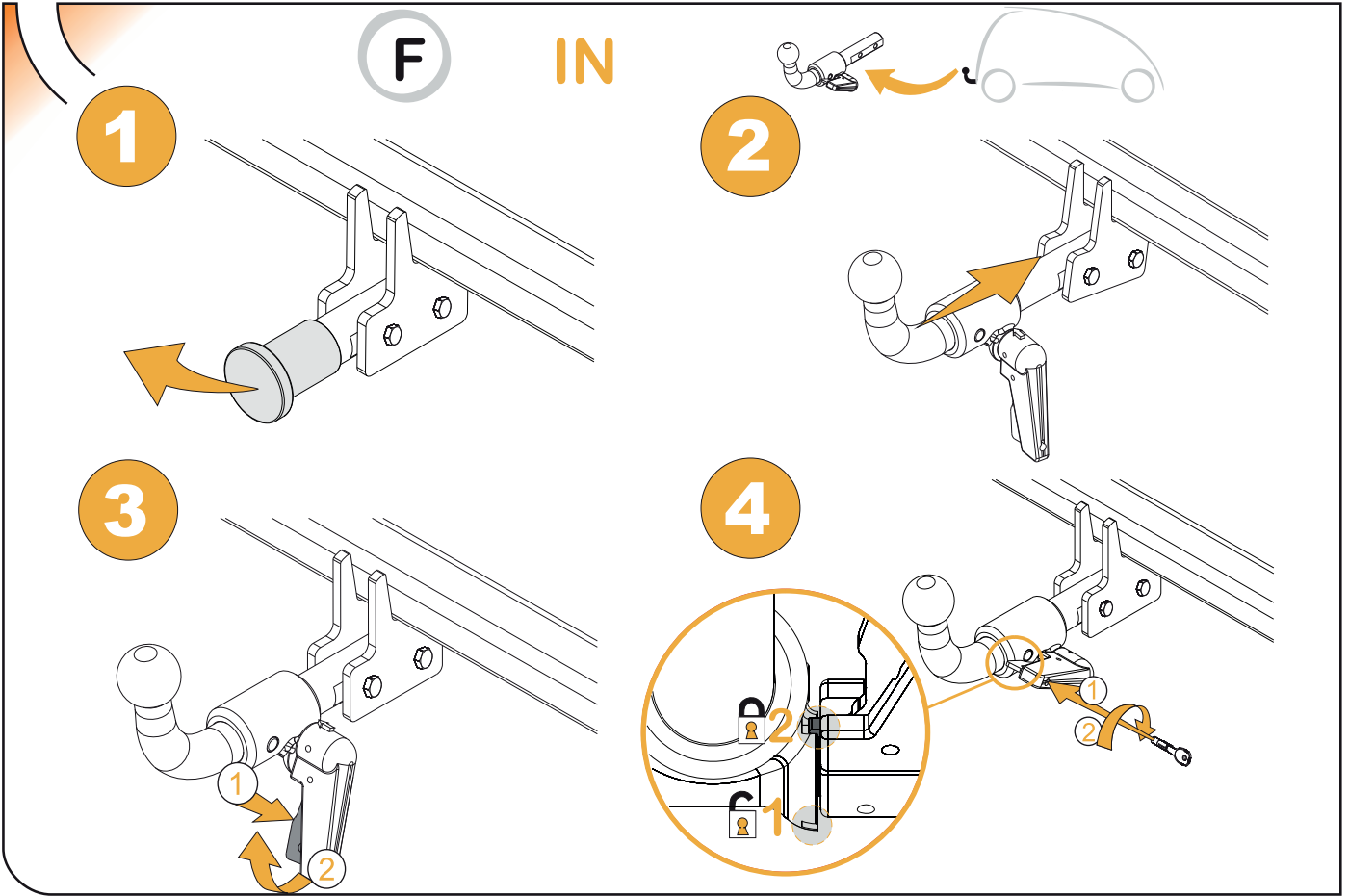

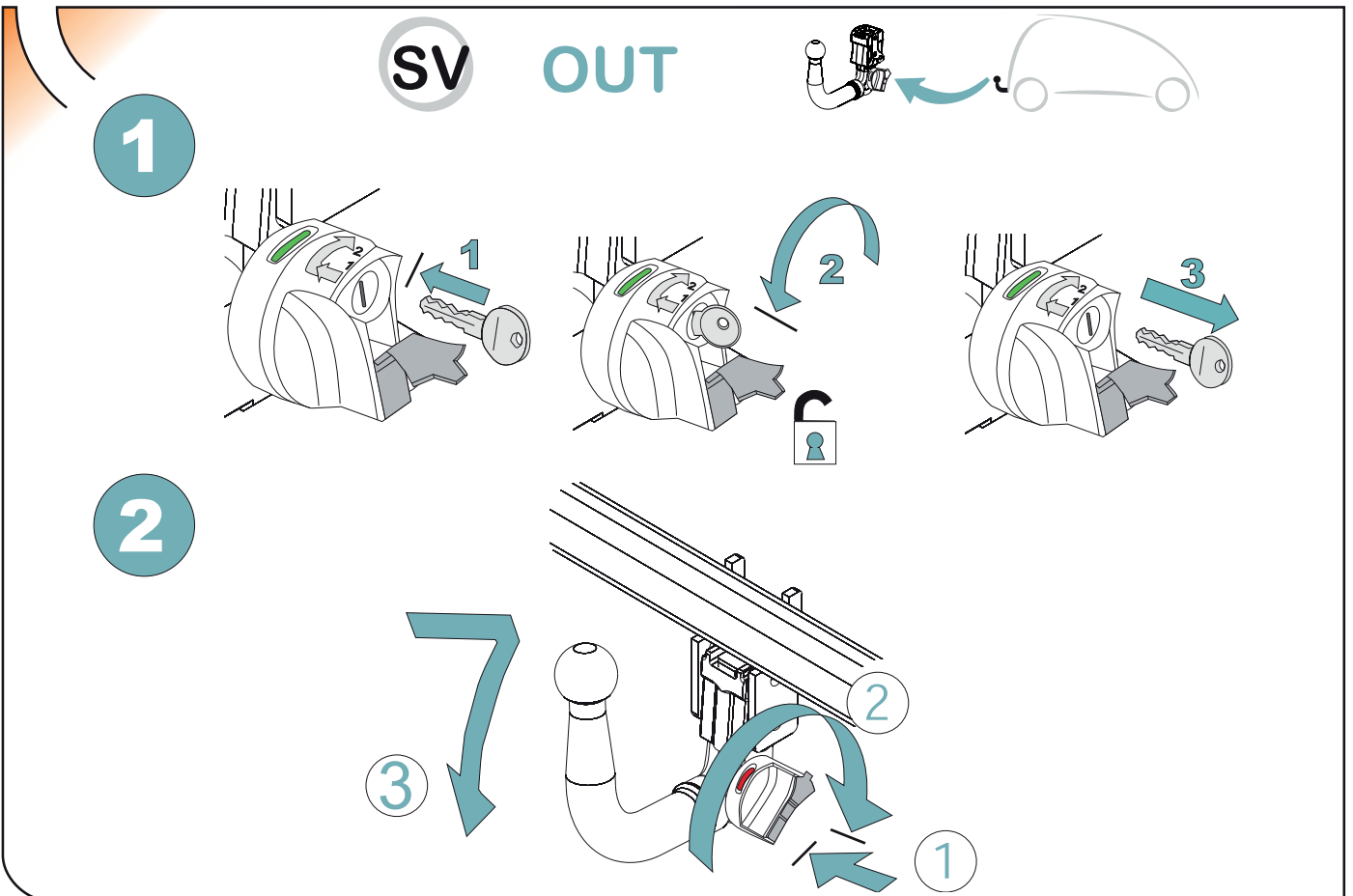
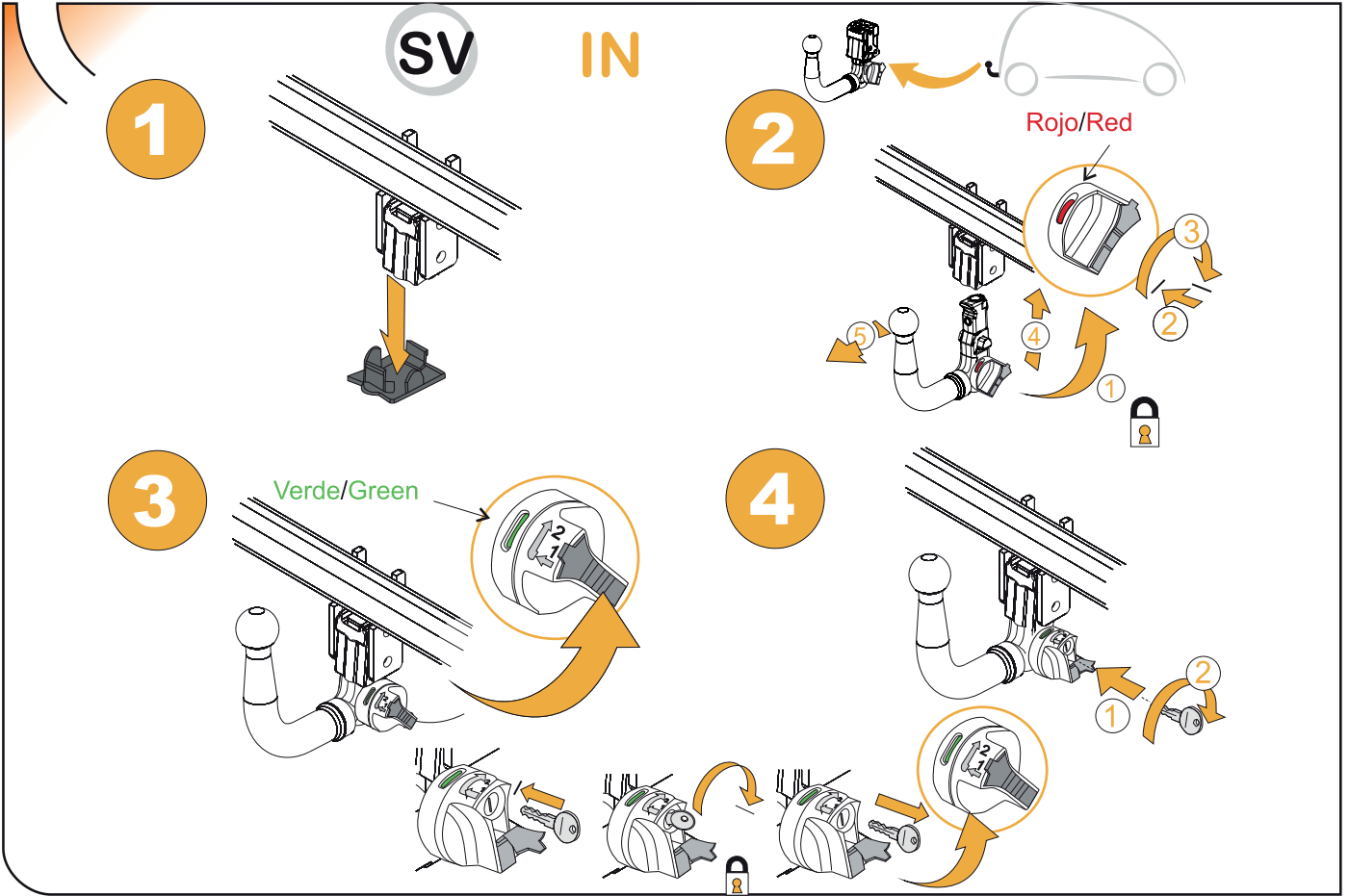



Diagram illustrating correct and incorrect hitching techniques. The top row shows three correct hitching methods, each marked with a green checkmark (✓). The bottom row shows three incorrect hitching methods, each marked with a red X (✗). The diagrams use horizontal lines to show the alignment of the hitch ball and the tow bar.



enganches

TowCar



TowBox[®]



TowCar[®]

enganches

 aragon

 TowBox®

ANEXO III

CERTIFICADO DE TALLER

D. _____, expresamente autorizado por la _____
domiciliada en _____, teléfono _____, dedicada
a la actividad de _____ n° de Registro Industrial _____ y n° de registro
especial _____.

CERTIFICA

Que la mencionada empresa ha realizado la/s Reforma/s y asume la responsabilidad de la ejecución,
sobre el vehículo marca....., tipo.....
variante..... denominación comercial
matrícula y n° de bastidor, de acuerdo con:

- La normativa vigente en materia de reformas de vehículos.
- Las normas del fabricante del vehículo aplicables a la/s reforma/s llevadas a cabo en dicho vehículo.
- El proyecto descriptivo de la/s reforma/s, adjunto al expediente.

OBSERVACIONES: (2)

Tipificada/s con el código de reforma/s.....
Reforma consiste en:

COLOCACION DE ENGANCHE _____

n° de identificación / marca de homologación

Type :

Fecha:

Firma y sello:

Fdo:

(1) En el caso de que la reforma sea efectuada por el fabricante se indicará N/A.

(2) Se debe especificar en este apartado OBSERVACIONES, la identificación de los equipos o sistemas modificados, garantizando que se cumple lo previsto en el artículo 6 del reglamento general de vehículos y, en su caso, en el artículo 5 del R. D. 1457/1986 de 10 de enero, por el que se regula la actividad industrial en talleres de vehículos automóviles, de equipos y sus componentes, modificado por 455/2010 de 16 de abril, por el que se modifica el R. D. 1457/1986 de 10 de enero por el que se regulan la actividad industrial y la prestación.

ES

1

ANEXO III
CERTIFICADO DE TALLER



2



3



IT

1

DICHIARAZIONE DI CORRETTO MONTAGGIO

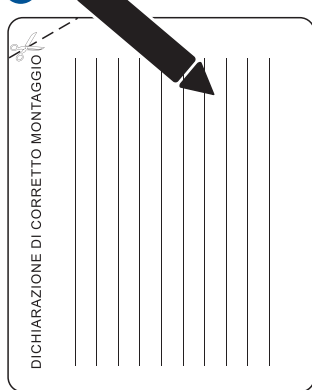

2

